

RL30120 SPECIFICATION

Visual Image of Test Chart

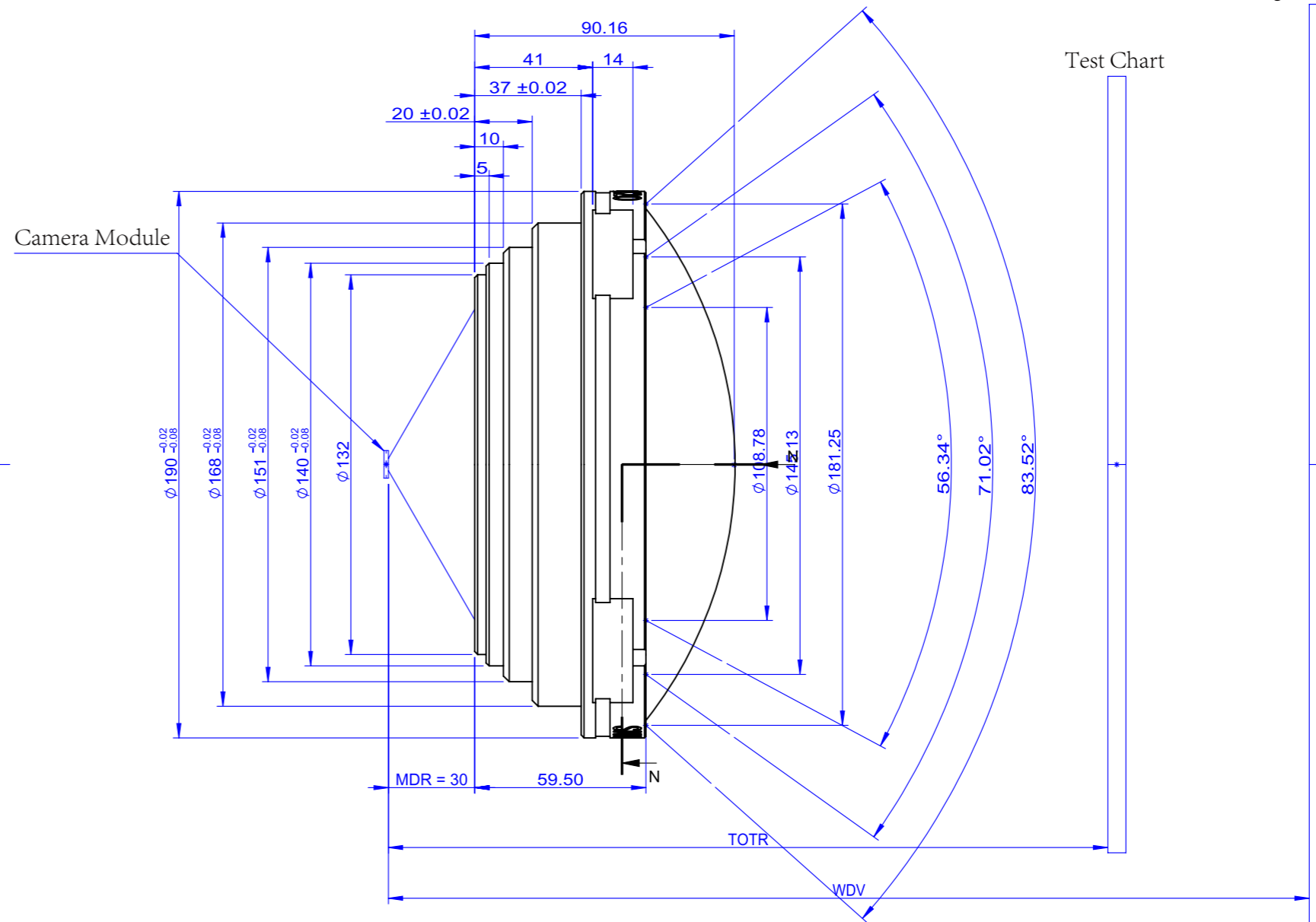
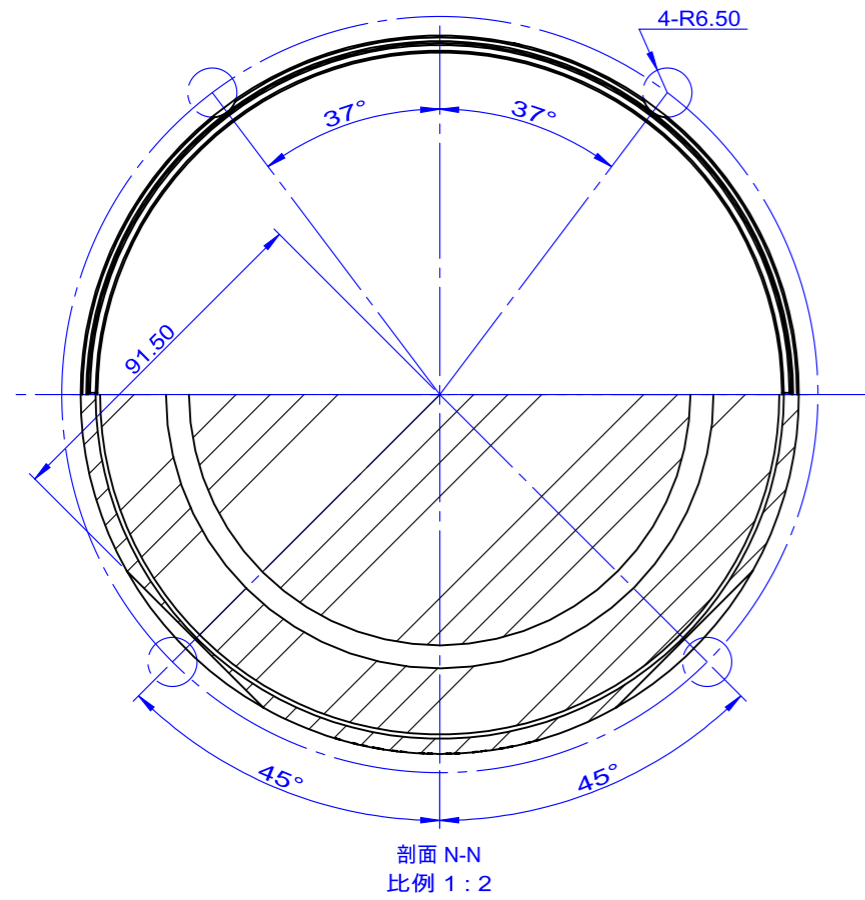

Notes:

1. The Chart Size is calculated according to the maximum field Angle of the relay lens;
2. WDV: Working Distance between the Visual Image of Chart and CCM top;
3. WDC: Working Distance between the Chart and Relaylens Object End;
4. MDR: Mounting Distance for Relay Lens from CCM top;
5. TOTR: Distance from the camera module to the test card.
6. The length and width of chart are calculated according to the chip specifications 4:3 or 16:9 of the camera module.

WDV	WDC	TOTR	Chart Size@Max FOV				Focal Length	300
			Diagonal	4:3(WxH)		16:9(WxH)		
5000	272.1	361.6	667.2	533.8	400.3	581.5	327.1	
6000	274.4	363.9	671.4	537.1	402.8	585.2	329.1	
8000	277.4	366.9	676.7	541.3	406.0	589.8	331.7	
10000	279.2	368.7	679.9	543.9	407.9	592.6	333.3	
20000	282.8	372.3	686.4	549.1	411.9	598.3	336.5	Distortion
50000	285.0	374.5	690.4	552.3	414.2	601.7	338.5	MAX FOV
80000	285.6	375.1	691.4	553.1	414.8	602.6	339.0	Weight
100000	285.8	375.3	691.7	553.4	415.0	602.9	339.1	Exit Pupil Aperture
1000000	286.4	375.9	693.0	554.4	415.8	604.0	339.7	MDR
100000000	286.5	376.0	693.1	554.5	415.9	604.1	339.8	Wavelength
								420-940 nm

Lontry		DESIGN	Derek	2018/6/26	MACHINE MODEL:	RL30120		
INFORMATION HEREIN SHALL NOT BE REPRODUCED IN ANY FORM WITHOUT COLIBRI WRITTEN PERMISSION		CHECKED			TITLE: RL30120 SPECIFICATION			
TOLERANCE CLASS NOT SPECIFIED		APPROVED			QTY: - TREATMENT:			
Dimensional tol./Masstol. ISO 2768-1:1999	tol.-class/Tol.-k	SCALE	A3	UNIT	mm	DWG/N	REV.	A
Geometrical tol./Form-u. Lagetol. ISO 2768-2:1999	tol.-class/Tol.-k	SCALE	1:5	WT(kg)	4.68	SHEET	1/1	